



REQUEST FOR PROPOSALS

ADVANCED METERING INFRASTRUCTURE **PROJECT**

Release Date: March 18, 2025

Submission Deadline: April 07, 2025, 4:00 P.M.

Contact Person:

Adrienne Carr, General Manager

acarr@nccwd.com

North Coast County Water District
80 Eureka Square, #219
Pacifica, CA 94044 www.nccwd.com

REQUEST FOR PROPOSALS (RFP)
Advanced Metering Infrastructure Project

Schedule of Important Events

Event	Date
RFP Issued	March 18, 2025
Deadline for Questions	March 26, 2025, no later than 4:00 P.M.
Responses to Questions Issued	March 31, 2025
Proposals Due to the District	April 07, 2025, no later than 4:00 P.M.
Board Meeting Award*	April 16, 2025
Coordination with Project Planning Team*	April 21, 2025, through Implementation
Notice to Proceed*	May 1, 2025
Required Implementation Completion*	February 28, 2026

****Estimated dates: The District reserves the right to modify this schedule at the District's discretion. Notification of changes in the response due date would be posted on the District website or as otherwise stated herein. All times and dates are Pacific Time.***

I. GENERAL SPECIFICATIONS

PURPOSE & INTRODUCTION

North Coast County Water District (District) is seeking proposals for an Advanced Metering Infrastructure (AMI) complete solution in order to improve the process of collecting water meter data in its service area, reduce non-revenue water currently unaccounted for, and to enhance the level of service offered to its customers by providing more frequent water consumption data.

The District anticipates a well-planned proposal that supports the implementation of a fully functional AMI system. It is the primary goal of the District to provide its customers with safe, reliable, and equitable access to water, as well as to ensure the fiscal and environmental vitality of the District's water supply system well into the future. The District expects that the AMI system will serve as an important tool for achieving its goals moving forward. The AMI system is expected to achieve the following objectives:

- (1) Provide cost savings to the District resulting from reductions in non-revenue water costs, including meter reading efficiency and accuracy, reduced meter repairs and replacements, and fewer manual meter reads;
- (2) Provide user functionality improvements for both customer and District software systems;
- (3) Enhance customer service by providing easy access to water consumption usage patterns, potentially reducing the instances of consumption complaints and requests and empowering customers to help manage their usage and costs;

REQUEST FOR PROPOSALS (RFP)
Advanced Metering Infrastructure Project

- (4) Reduce technology susceptibility to damage or errors; and
- (5) Provide the District access to near real-time meter diagnostics and consumption data, including advanced leak detection, monitoring of tampers, and backflow.

The purpose of this Request for Proposal (RFP) is to select a Proposer to provide all equipment, materials, training, and supervision to analyze, scope, install, program, calibrate, adjust, document, and test the total system. This subsection contains, in general terms, the overall objectives of the District and is issued with the intent of obtaining the services for a complete AMI system.

The Proposer, with its own forces, or through District-approved joint ventures (including General Contractor) shall perform all the work described in the Specifications, included here as **Exhibit A**, enabling the District to achieve the objectives described in this document. The Proposer shall acknowledge that a strict compliance schedule exists and that time is a prominent concern for this project.

Each Proposal provided for consideration by the District is responsible for obtaining information on the conditions and restrictions involved with meeting the obligations and providing the services as set forth in this RFP. The failure or omission of a Proposer to obtain adequate information will in no way relieve the Proposer of any obligation with respect to this RFP or to an associated contract.

A. NEW AND UNUSED

All equipment, parts and materials shall be new, unused, and of the manufacturer's model specified by the District (unless otherwise noted herein). All materials shall have written specifications to withstand the intended service. Equipment design shall be one of durability and longevity.

B. PROJECT COMPLETION DATE

The required completion date is February 28, 2026. This date is set by the grant funding agreement schedule and is not adjustable. This completion date applies to the completion of construction and documentation but does not apply to support and training, which can occur after that date.

C. BEST MODERN PRACTICES

All work, including design, shall be performed and completed in accordance with the best modern practices, further, no detail necessary for safe and regular operation shall be omitted.

D. MINIMUM QUALIFICATIONS

The following are minimum qualifications and licensing requirements that the Proposer must meet in order for their proposal submittal to be eligible for evaluation. The District

REQUEST FOR PROPOSALS (RFP)
Advanced Metering Infrastructure Project

requests a one-page or appropriate-length document as part of your Proposal response, to clearly show compliance with these minimum qualifications. Proposals that are not clearly responsive to these minimum qualifications may be rejected by the District without further consideration:

1. Four or more years of related experience as an individual firm. If proposing as a joint venture, the combined total related experience of partner firms must be five or more years.
2. Description of experience designing and implementing AMI meters, endpoints, and infrastructure for a municipal service area of similar size.

II. PROPOSALS

A. SUBMITTALS

All submittals become the property of the District and will not be returned. All conditions contained in this RFP are considered accepted by the Proposer in any proposal submitted.

The accepted proposal will become part of the formal contract and will be included as an attachment to the contract. The proposal pricing must remain in effect for at least ninety (90) days after the date of submission. Proposals having any erasures or corrections thereon may be rejected unless explained or noted over the signature of the Proposer. Proposers shall submit proposals on company letterhead and be signed with an authorized signature. By signing this proposal, the undersigned hereby acknowledges that they are authorized and duly bound to execute this document on behalf of the company and that his/her signature is binding on the company.

B. ORGANIZATION OF PROPOSALS

The Proposer shall include in their proposal, at a minimum, the information outlined below in a manner which demonstrates the Proposer's competence and qualifications for the satisfactory performance of services identified in this RFP. The Proposer shall attach six (6) separate exhibits, as described below, to the cover letter proposal:

- I. Statement of Qualifications
- II. Partner Relationships
- III. AMI Complete Solution Overview
- IV. Response to Technical and General Specifications
- V. Installation, Training, and Activation
- VI. Completed Project Pricing

REQUEST FOR PROPOSALS (RFP)
Advanced Metering Infrastructure Project

Proposals shall include the following sections:

1. **Statement of Qualifications:** Provide descriptions of previous successful implementation of at least three similar AMI projects for water systems of similar size (at least 10,000 services) within the past five years. Reference and contact information must be included. References may be checked. Include a listing of each key staff person in the firm or specific individual who will be assigned to the project and background information demonstrating their capabilities and qualifications to perform the assigned task. For each individual, provide current professional registrations, applicable related experience, educational background, and years of experience with the team. In addition, include the one-sheet or appropriate length minimum qualifications document as described above in Section I.D. "Minimum Qualifications".
2. **Partner Relationships:** Provide description of Proposer's partner relationships with the products that they are quoting.
3. **AMI Complete Solution Overview:** Provide an overview of AMI technology, integration, and operation of the proposed AMI system. Responses will summarize all system components and insights about the identified AMI goals and challenges as they are pertinent to the District. At a minimum, the AMI Complete Solution Overview should include:
 - System type (i.e., cellular, radio frequency, or hybrid);
 - Meter retrofit compatibility;
 - System name;
 - Distributor name;
 - Estimated project timeline (system implementation must be complete no later than February 28, 2026, with the exception of training and support which can occur after that date);
 - System type;
 - Endpoint technology;
 - Customer portal name;
 - System lifespan;
 - Summary of installation, training, and startup plans; and
 - Estimated propagation within the District (as applicable with completion of

REQUEST FOR PROPOSALS (RFP)
Advanced Metering Infrastructure Project

radio propagation study)

The District has considered a life-cycle analysis of its existing meter fleet, and has determined that a sustainable full-lifespan utilization approach for meters not approaching the end of their designed life will provide a solution that aligns with the grant funds awarded to the District for this project, the implementation schedule, and the District's capacity to replace meters in-house on a continual as-needed basis as they age out of their operational functionality. The District intends to optimize the useful life of its existing meters by electing to retrofit either all meters or meters under an age limit threshold to become AMI-compatible. Proposals shall present a base scope implementation scenario with additive alternate items as shown below:

Base Scope: All meters will be retrofitted with an AMI-compatible endpoint or an AMI-compatible endpoint and a new register, depending on the Proposer's retrofit technology solution. Proposals will include the specific mechanism of retrofit, including how the AMI endpoint will be installed into the existing meter apparatus.

Proposals should also include additive alternatives, as described below. These alternatives shall be included as additional scope and bid items separate from the base scope pricing. The District will have the option to include any of the following additive alternatives in the final contract:

- (1) Additive Alternative 1 – Meter Replacement > 15 Years: Proposers should include an additional cost item to replace meters older than 15 years of age with new, AMI-compatible meters and endpoints. Meter changeout mechanism and installation will be outlined in the Proposal. The implementation scenario assumed for this additive alternative is that meters younger than 15 years of age would be retrofitted with AMI-compatible endpoints or endpoints and registers, depending on the AMI technology outlined in the Proposal, and the retrofit estimate in the Base Scope would not change. For the purpose of estimating a cost for this alternative, all meters that have an unknown age estimate in Table 1 should be assumed to be greater than 15 years old.
- (2) Additive Alternative 2 – Meter Replacement 11-15 Years: Proposers should include an additional cost item to replace meters between 11 and 15 years of age with new, AMI-compatible meters and endpoints. Meter changeout mechanism and installation will be outlined in the Proposal. The implementation scenario assumed for this additive alternative is that meters younger than 10 years of age would be retrofitted with AMI-compatible endpoints or endpoints and registers, depending on the AMI technology outlined in the Proposal, and the retrofit estimate in the Base Scope would not change. This cost item would be separate from and in addition to the retrofit for meters younger than 11 years of age and replacement of meters older than 15 years of age (included in Additive Alternative 1).

REQUEST FOR PROPOSALS (RFP)
Advanced Metering Infrastructure Project

- (3) Additive Alternative 3 – Meter Replacement 7-10 Years: Proposers should include an additional cost item to replace meters between 7 and 10 years of age with new, AMI-compatible meters and endpoints. Meter changeout mechanism and installation will be outlined in the Proposal. The implementation scenario assumed for this additive alternative is that meters younger than 7 years of age would be retrofitted with AMI-compatible endpoints or endpoints and registers, depending on the AMI technology outlined in the Proposal, and the retrofit estimate in the Base Scope would not change. This cost item will be separate from and in addition to the retrofit for meters younger than 7 years of age and replacement of meters older than 10 years of age (included in Additive Alternatives 1 and 2).
- (4) Additive Alternative 4 – Meter Replacement 0-7 Years: Proposers should include an additional cost item to replace meters between 0 and 7 years of age with new, AMI-compatible meters and endpoints. Meter changeout mechanism and installation will be outlined in the Proposal. When combined with Additive Alternatives 1 through 3, the implementation scenario assumed for this additive alternative is that no meters will undergo a retrofit, and all meters will be replaced. This cost item will be separate from the Base Scope and replacement scenarios outlined in Additive Alternatives 1 through 3. A full meter changeout implementation scenario would consist of the aggregate cost of Additive Alternatives 1 through 4, in addition to the Base Scope items of AMI infrastructure and system implementation.

Proposers may specify a radio frequency (RF) system, a cellular system, or a hybrid system that includes both RF and cellular components. If a propagation study has been conducted previously, this information should be included in the proposal; however the lack of a propagation study completed prior to the issuance of this RFP will not preclude the selection of a particular vendor from the decision to award this project.

4. **Response to General and Technical Specifications**: Provide an organized list of any proposed modifications or exemptions to the technical and general specifications listed in **Exhibit A**. Provide a brief explanation for each proposed exemption.
5. **Installation, Training, and Activation**: The Proposer will provide a written, detailed implementation plan describing how and when the hardware and software will be installed and fully ready for District operation by the Project Completion Date listed above. Ensure all the following are included:

REQUEST FOR PROPOSALS (RFP)
Advanced Metering Infrastructure Project

Implementation Plan Document

The Proposer will develop a detailed Implementation Plan document. The implementation plan will be used to monitor and assess the progress and provide system documentation. The Implementation Plan document will at a minimum include:

- Installation of AMI endpoints or registers and AMI endpoints on retrofit-compatible meters
- Installation of new meters for those that are incompatible with a retrofit
- AMI system component installation and construction, including base stations, repeaters, collectors, and antenna
- Hardware installation and configuration
- Software installation and setup
- Testing
- Validation
- Client deployment
- User training and documentation

In addition to the Implementation Document, Proposer must address the following:

Software Installation:

- a. Describe any software installation support that is included at no additional cost to the District, above and beyond that required by this RFP, including as described in the Specifications in **Exhibit A**.
- b. Describe additional software or cellular installation support that can be purchased for additional cost.

AMI System Installation:

- a. Describe any infrastructure and hardware components required for the functional operation of the system not included in this quote.
- b. Describe the meter box lid requirements for AMI system installation and functional communication from AMI endpoints to base stations or the central District communication center.

REQUEST FOR PROPOSALS (RFP)
Advanced Metering Infrastructure Project

- c. Describe the space, power, and/or cellular network requirements needed for the proposed AMI system within the framework established in this RFP and the existing District assets on which AMI infrastructure will be placed (i.e., water tanks).
- d. Describe the backup power requirements required for the functional operation of the system.
- e. Describe any additional requirements that are not currently specified in this RFP.

Documentation:

- a. Describe the documentation provided by the Proposer at no additional charge under the terms of this proposal, including any submittals, shop drawings, test reports, close-out documents, and O&M manuals, including but not necessarily limited to those described in the Specifications in **Exhibit A**.
- b. Describe the costs for any optional documentation beyond that described in item a above.

Implementation:

- a. Detail an installation schedule for each of the three implementation scenarios based on your experience and ensuring a system-wide completion date no later than February 28, 2026, with the exception of training which can be completed later than that date. The Proposer shall include a schedule reflecting the proposed completion date of retrofit installation, meter changeouts, AMI infrastructure setup, system testing, and system setup. Any assumptions used to generate the schedule should be clearly stated. Assume a notice to proceed date of May 1, 2025.

Training: Proposer must list in the cost proposal whether the training is provided offsite or onsite, training duration, and the training level. The Proposer will work with District IT consultant to determine exact training requirements prior to installation.

- a. Describe any training that is included at no additional cost to the District above and beyond that is required by the Specifications in **Exhibit A**.
- b. Describe any training services available for additional cost.
- c. Describe where the training will take place.

- 6. **Completed Project Pricing:** The Proposal shall complete the form in **Exhibit D**. Proposal shall include the full price for the system, including delivery, installation, integration, and acceptance testing. The Proposal shall include an allocation for the

REQUEST FOR PROPOSALS (RFP)
Advanced Metering Infrastructure Project

appropriate sales and use tax. Proposer should include whether or not the equipment will be leased or owned by the District, and any subscription fees that will apply for recurring software licensing, if applicable. Ensure the following are addressed:

Pricing Information:

Pricing shall be included for the base scope and separately for each of the Additive Alternatives as follows:

Base Scope (Complete Meter Retrofit): Proposals will include the pricing for each item included in the proposal, assuming that all compatible meters will be retrofitted for integration into the new AMI network. The number of meters to be replaced for each Additive Alternative will be based on the meter age totals shown in Table 1 and in the “assumed quantity” column of **Exhibit D**.

- (1) Additive Alternative 1: Pricing will be included for the replacement of meters 15 years of age or older. This includes cost of the meters to be replaced and installation.
- (2) Additive Alternative 2: Pricing will be included for the replacement of meters between 11 and 15 years of age. This includes cost of the meters to be replaced and installation.
- (3) Additive Alternative 3: Pricing will be included for the replacement of meters between 7 and 10 years of age. This includes cost of the meters to be replaced and installation.
- (4) Additive Alternative 4: Pricing will be included for the replacement of meters between 0 and 7 years of age. This includes cost of the meters to be replaced and installation.

Include the pricing for each item included in your proposal as applicable for the base scope and the four Additive Alternatives and the applicable basis for the unit rate pricing. In addition, include pricing for the following:

- a. AMI system infrastructure including base stations, collectors, and repeaters
- b. AMI system software and any other required software
- c. Replacement of meter lids
- d. Subscriptions, including cellular subscriptions if applicable
- e. Any other costs not included above.

REQUEST FOR PROPOSALS (RFP)
Advanced Metering Infrastructure Project

C. DEADLINE FOR DELIVERY OF PROPOSALS

All proposals shall be sent via electronic mail to acarr@nccwd.com no later than 4:00 P.M. Pacific Standard Time on April 07, 2025.

Proposals received after the above deadline will not be eligible for consideration. The deadline will be strictly adhered to. Late proposals will not be considered. Proposals which do not include all requested information and required documentation may be considered non-responsive.

The District will not be liable for any costs incurred by the Proposer in preparation of a proposal submitted in response to this RFP, in the conduct of a presentation, in facilitating site visits or any other activities related to responding to this RFP.

D. QUESTIONS

Questions regarding this project may be directed to the General Manager, acarr@nccwd.com. Questions are due by March 26, 2025. Answers to questions will be issued by March 31, 2025.

E. REJECTION OF PROPOSALS

The District reserves the right to reject any and all proposals, and to waive any irregularities of information in the evaluation process.

F. NOTIFICATION TO UNSUCCESSFUL PROPOSERS

Proposers, whose proposals have not been selected, will be so notified by electronic mail.

G. MORE OR LESS

Quantities are estimated only and shall be priced on a MORE OR LESS basis. For the purpose of comparison, prices shall be made on the various components in the quantities listed in the proposal. Listed quantities shall not be considered firm estimates of requirements for the year, nor shall the District be bound or limited to quantities listed.

H. DELIVERY

Each Proposer is required to list on the proposal the number of calendar days he/she expects delivery to be made at the destination, in terms of time interval, following placement of order. Time of delivery is important and will be considered in the evaluation of the proposals. Failure to include a specific number of calendar days may be sufficient grounds for rejection of Proposal. Upon delivery, the equipment shall be thoroughly tested in operation by an authorized representative of the District to check on the performance of the equipment and operation of the unit as a whole.

REQUEST FOR PROPOSALS (RFP)
Advanced Metering Infrastructure Project

I. PROPRIETARY INFORMATION

Any proprietary information revealed in the proposal should, therefore, be clearly identified as such.

J. TAXES & LICENSES

All lump sum prices shall include sales tax in the proposal price unless otherwise noted. The successful Proposer is expected to obtain and pay for all required Federal, State, and local licenses and permits required for purchase and installation.

K. RESPONSIBILITIES

Proposer will provide the AMI infrastructure, installation, retrofit, support, implementation, and other services as required by the District in the final contract. These products, support and services shall be accompanied by the AMI Complete System documentation and include system specifications that describe the setup and startup of the AMI system.

III. EVALUATION OF PROPOSALS AND AWARD

A. PROPOSAL EVALUATION

Proposals will be evaluated on the best probability of the Vendor meeting the District's objectives outlined in this request. The evaluation will be based on the benefits to the District and the Vendor's qualifications. The Vendor's response may be used to select a short list of candidates for presentations; however, a Vendor may be selected based solely from their proposal score.

The District will use the following factors to evaluate the proposals:

1. Comprehensive AMI retrofit (base scope) and meter replacement system (additive alternates) that meets project specifications. (15%)
2. Installation, integration, testing, and training: Evaluation based on the implementation plan, timeline, and user training plans. (15%)
3. Respondent experience and qualifications related to AMI system implementation and installation in a like environment. (10%)
4. Respondent references for comparable services. (10%)
5. Total cost for services. (40%)
6. RFP response document completeness. (10%)

REQUEST FOR PROPOSALS (RFP)
Advanced Metering Infrastructure Project

Following receipt and review of the proposals by the District, selected firm(s) may be invited to an interview with the District. The decision to interview the respondents will be at the District's sole discretion based on evaluation of each respondent's proposal.

Although the District may conduct interviews to select final candidates for award of this work, it is not the District's intent to seek extensive clarification of the proposals received. Therefore, it is to the benefit of the respondent to provide an explicit, detailed, and complete discussion of the work in the proposal.

B. CONTRACT DEVELOPMENT

The District intends to enter into a contractual agreement with the apparent successful Proposer for providing the needed services to achieve the earliest possible full implementation date. Therefore, contract negotiations will proceed following award of the apparent successful proposal. The content of the Request for Proposals and the successful proposal will become integral parts of the contract but may be modified by the provision of the contract. If a contract, for any reason, cannot be negotiated, another Proposer may be selected based on the next best Proposer. An example contract is attached to this RFP as **Exhibit B**.

C. AWARD

The District reserves the right to be the sole judge of the acceptability of a response. This is a competitive negotiation process. The District will evaluate the proposals to determine the most responsive proposal.

There is no commitment on the part of the District to accept the lowest cost proposal or the conditions imposed by the Proposer as a requirement of acceptance. Although these are evaluation factors, the District reserves its unqualified right, without limitation, to consider any and all other factors that may significantly impact the proposal. The District is an equal opportunity employer and encourages all qualified small and disadvantaged businesses or consulting firms to respond.

The final decision is the sole decision of the District, and the respondents to the RFP have no appeal rights or procedures guaranteed to them.

D. NEGOTIATION

The District reserves the right to negotiate any and all elements of this Proposal.

IV. SCOPE OF WORK

The District wishes to contract with a Proposer to retrofit existing meters and replace a selection of meters to provide an AMI system including software and billing system based on the attached exhibits contained in this document. The Proposer will coordinate and consult with the District's General Manager, the District's consulting team, the District's design team, and the District's General Contractor, to develop, plan, coordinate,

REQUEST FOR PROPOSALS (RFP)
Advanced Metering Infrastructure Project

organize, and manage the Project. This will include attending and providing updates at OAC meetings as necessary.

A. EXISTING ENVIRONMENT

The District is located in the City of Pacifica in San Mateo County, California. Its service area boundaries closely correspond to the City of Pacifica boundaries, with small portions located in unincorporated San Mateo County. The District's water service area is shown in **Exhibit C**. Elevations in the existing service area range from approximately 15 feet above mean sea level to 700 feet above mean sea level.

The District's water distribution system contains 32 pressure zones with 13 tanks as shown on **Exhibit C**, attached. Typical meter installations are in boxes with one meter per box and concrete lids. Lids have pre-drilled holes penetrating all the way through the concrete. Meters are generally located in sidewalks or driveways.

In order to prepare a radio propagation analysis as part of the vendor's proposal, a list of all meter location addresses and District-owned properties (e.g., tank sites, buildings, and corporation yards) may be made available by the District upon request.

B. DISTRICT SOFTWARE

The District's accounting and billing software is Tyler Technologies Incode Version 10. The District employs electronic asset management through GIS software, and may provide Proposers with existing meter locations upon request.

C. DISTRICT WATER METER INVENTORY

The District's existing water meter inventory is shown in Tables 1 and 2 below. The District's service area contains 12,718 meters, of which 12,637 are in operation and 81 that are currently turned off. The majority of meters within the system are the Sensus SR-II model with touch-read capacity. There are approximately 150 drive-by radio meters, all read on a bimonthly basis, with a small number of manual-read meters.

REQUEST FOR PROPOSALS (RFP)
Advanced Metering Infrastructure Project

Table 1. Meter Age and Type Totals

Meter Age (Based on Installation Date)	Meter Type						Total Number of Meters
	Low Boy	Omni	Rockwell	Sensus ¹	SR II	Other	
1-3 Years	0	3	3	1,291	10	3	1,310
4-6 Years	0	0	6	558	2	0	566
7-10 Years	2	16	129	3,222	73	2	3,444
11-15 Years	0	19	5	2,907	69	1	3,001
16-20 Years	0	0	0	3,021	14	0	3,035
Over 20 Years	1	1	2	1,312	43	0	1,359
Unknown	0	0	0	1	0	2	3
Total Number of Meters	3	39	145	12,312	211	8	12,718

¹ For the purposes of this RFP, it is assumed that the meters listed in the “Sensus” column are comprised of at least 95% Sensus SR-II models, with the remaining portion being Sensus Omni models. The model and size of these meters should be confirmed prior to installation.

Table 2. Meter Age and Size Totals

Meter Age (Based on Installation Date)	Meter Size										Total Number of Meters
	5/8”	¾”	1”	1 ½”	2”	3”	4”	6”	8”	Unknown	
1-3 Years	1,187	35	67	5	4	9	3	0	0	0	1,310
4-6 Years	476	36	40	4	7	2	0	1	0	0	566
7-10 Years	3,251	52	104	14	14	2	0	2	0	4	3,444
11-15 Years	2,780	29	125	24	34	5	4	0	0	0	3,001
16-20 Years	2,646	140	226	6	15	1	0	1	0	0	3,035
Over 20 Years	1,042	28	243	26	16	2	1	0	1	0	1,359
Unknown	1	0	2	0	0	0	0	0	0	0	3
Total Number of Meters	11,383	320	807	80	90	21	8	4	1	4	12,718

Typical meter locations within the District are in front of homes, either in yards or adjacent to a driveway. 90% of meter box lids are assumed to be concrete, with the remaining 10% composed of Fibrelite polymer. Though the District would ideally prefer to retain its existing meter box lids, it will entertain lid replacement options. If a lid replacement is needed for your system, please indicate this in the proposal and indicate the lid replacement costs and quantities in **Exhibit D**.

REQUEST FOR PROPOSALS (RFP)
Advanced Metering Infrastructure Project

It is assumed that AMI infrastructure (e.g., base stations, repeaters, collectors, etc.) will be placed on existing District assets, including water storage tanks. Tank heights, PG&E power access, and locations may be made available by the District upon Proposer request to aid in optimization of radio propagation and overall system operation. If a propagation study is performed, please assume only District-owned infrastructure is available to implement an AMI network and include the results of the propagation study as part of the Proposal package. Proposals may also include a secondary option to place AMI infrastructure on non-District owned assets (including nearby schools, fire stations, and other buildings) to increase propagation while minimizing the addition of additional infrastructure. Additionally, Proposals may include a hybrid RF and cellular system to increase propagation in areas of the District where there are RF coverage gaps. If a Proposer presents a hybrid cellular and RF option as part of their proposal, please indicate the combined cellular and RF software costs and subscriptions in the pricing section.

D. DISTRICT RESPONSIBILITIES

1. Access to Plans and AMI system narrative in PDF format.
2. Oversight of installation, planning, and implementation on the District's schedule for proposal preparation tasks, access granted by a formal request for appointment.
3. List of any custom configurations that are required at the time of installation.
4. All AMI network, software, and billing system configurations.

E. DEFECTS CORRECTIONS

Throughout implementation and during the terms of all support and maintenance agreements, including all renewal periods, Proposer will correct all defects to the extent those defects originate from the acts or omissions of Proposer's products or personnel.

V. LIST OF EXHIBITS AND ATTACHMENTS

Exhibit A: Technical Specifications
Exhibit B: NCCWD Example Contract
Exhibit C: Existing District Service Area Map and Hydraulic Profile
Exhibit D: Standard Pricing Estimate Form

Meter locations, tank locations and heights, and power access locations may be made available upon request.

EXHIBIT A
SPECIFICATIONS

Technical Specifications

1. Metering Infrastructure

- 1.1. Proposal for new meters shall be magnetic-drive, positive-displacement meters using an oscillating piston. Meters shall be Sensus SR II or approved equal for meters less than or equal to 1-inch. Meters shall be Sensus OMNI or approved equal for meters larger than 1-inch.
- 1.2. Proposal for retrofitted meters shall be for registers or registers and endpoints compatible with the proposed AMI communication system. All materials required for meter retrofits shall be specified in the proposal.
- 1.3. The register shall read in US Gallons.
- 1.4. Meters and registers must be capable of directly interfacing with various independent AMI End Point Transmission Devices without the need for any on-site register programming.
- 1.5. Meters shall meet current Safe Drinking Water Act lead free standards.
- 1.6. Meters shall comply with all American Water Works Association (AWWA) standards including but not limited to: C700, C701, C702, C707, C710, C712 or C713.
- 1.7. Registers and endpoints shall comply with all AWWA standards including but not limited to: C700, C701, C702, C707, C710, C712 or C713.
- 1.8. Meters 2" in size and larger must be equipped with valves for in-line test provisions. All meter assemblies shall be tested and shall be in compliance with the requirements of the latest revision of the AWWA Standards.
- 1.9. All AMI System components interfacing with water are required to be waterproof.
- 1.10. NICOR or similar wire connectors are permissible for wire splicing for the retrofit.
- 1.11. Provide wire protection against gophers and varmint.
- 1.12. The preferred meter lid replacement is Old Castle Fibrelyte or equivalent, as meter box lid replacement is applicable. If located in a vehicle travel way, meter lids must be traffic rated.
- 1.13. All equipment must comply with current Federal Communications Commission (FCC) requirements.
- 1.14. The proposed system must operate on a dedicated, FCC licensed

frequency or District-approved unlicensed frequency or cellular system. If a repeater or booster is proposed, define how these components will affect system functionality.

- 1.15. If the addition of extra height to place boosters, collectors, or other AMI components would be advantageous to improve propagation, the proposal may include an option to coordinate placement of AMI infrastructure on non-District-owned assets (such as nearby schools, fire stations, police stations, etc.).
- 1.16. The AMI End Point Transmission Device shall be designed to have a battery life of 20 years or more.
- 1.17. Each End Point Transmission Device shall function as a true two-way network and allow on-demand real-time data requests from the AMI and/or meter data management software.
- 1.18. The two-way water End Point Transmission Device shall provide time synchronized daily reads, at a minimum.
- 1.19. Each AMI End Point Transmission Device clock date and time settings shall be updated to match reference data and time that shall be regularly provided to the meter.
- 1.20. The End Point Transmission Device shall be capable of storing meter data including date stamps down to at least daily intervals for a minimum of 60 days in non-volatile memory.
- 1.21. All End Point Transmission Devices shall have the capability to receive and process commands and system firmware updates to eliminate the need to manually perform the update function at each locale. AMI modules must support group firmware updates to reduce system maintenance time.
- 1.22. The AMI End Point Transmission Device shall employ actionable alerts for all of the following:
 - 1.22.1 Tamper Alert or Meter disconnected
 - 1.22.2 Invalid Read
 - 1.22.3 Small Leak Detected
 - 1.22.4 Large Leak Detected
 - 1.22.5 Continuous flow detected (number of days)
 - 1.22.6 Intermittent flow detected (number of days)

1.22.7 No Flow detected – Specific period of time set by the District

1.22.8 Reverse Flow / Backflow

1.22.9 High Flow Rate Detected – Specifics set by the District

1.22.10 Battery Health – for preventative maintenance

- 1.23. The Data Collectors shall communicate on demand to AMI End Point Transmission Devices.
- 1.24. The Data Collectors Software shall allow self-diagnosis of any problems associated with the backhaul of the communication system.
- 1.25. If proposing a radio frequency network, the onsite Head End Server or Hosted Server shall act as the central collection point for the data within the system. The server collects data from all of the Data Collectors and stores the gathered data in a secure database.
- 1.26. Once data is stored and analyzed, the data shall be available for display via an easy-to-use, web-based graphical interface.
- 1.27. If proposing a radio frequency network, the proposal should discuss head end server options.
- 1.28. The data will be available via a user interface that will allow for analysis, as well as bill generation.
- 1.29. Proposal shall discuss if and how the AMI system collects, retrieves, and analyzes acoustic leak detection and pressure data.

2. Meter Data Management Software

- 2.1. The Meter Data Management Software shall manage and archive data for five years such that it can be accessed by any District computers, handheld devices both locally and remotely via the web.
- 2.2. The Meter Data Management Software must have flexible meter reading data formats that are compatible with the District's current billing application (Tyler Technologies Incode Version 10).
- 2.3. The Meter Data Management Software shall be used to generate reports; view demand graphs, determine usage patterns, enforce watering restrictions, zone analysis, etc.
- 2.4. Each AMI End Point Transmission Device-generated alert shall be accompanied by the duration the alert has been active for, which shall be stored and optionally sent out by the server.

- 2.5. The User Interface shall permit the sending of alert outages, tampering, out-of-bounds system operating parameters to appropriate District personnel via cell phone, pager, or e-mail.
- 2.6. The vendor shall offer a secure web-based application for individual homeowner access to consumption data with mobile phone access app.
- 2.7. The homeowner shall have access to reports for yearly, monthly, and hourly data and be allowed to set parameters for email or text alerts.
- 2.8. Consumption data shall be correlated with climatological data.
- 2.9. Reports shall be available in graphical and table views for reading and consumption for various intervals.

3. Installation

- 3.1. Water Meter Retrofit (Base Scope) shall be proposed as a cost line item with per-meter unit type.
 - Standard installation of register and/or endpoint shall be for meter retrofit without further modification of meter lid or box (see “Base Scope” cost line item);
 - Installation may include replacement of the meter lid if deemed necessary by the Contractor (see “Replacement of Meter Lids” cost line item).
 - During retrofit, all applicable meters shall have an AMI endpoint or AMI endpoint and register installed on the existing meter.
 - During installation, Contractor shall inventory upstream and downstream pipe materials of the meter. This data will be included with GPS locations.
 - All District meter locations shall be submitted as a table of GPS locations and photographs with associated meter and endpoint number and account number.
- 3.2. Water Meter installation shall be proposed as an additive alternative cost line item.
 - Where requested, installation cost line items shall be proposed according to a meter age threshold as specified in the pricing schedule.
 - Standard installation shall be for meter replacement without further modification of lid or box.

- If needed for AMI system functionality, installation may include replacement of meter lid or entire meter box.
 - During installation all meters will be replaced with new meters of the same size as the meter to be replaced.
 - During installation, Contractor shall inventory upstream and downstream pipe materials of the meter. This data will be included with GPS locations.
 - All District meter locations shall be submitted as a table of GPS locations and photographs with associated meter and endpoint number and account number.
- 3.3. If proposing a RF network, the manufacturer of the selected AMI solution will perform the installation of the Head End Server/Computer and software.
- 3.4. Submit plan for Data Collector installations and complete deployment.
- 3.5. The manufacturer of the selected AMI solution will perform the installation of all infrastructure required to support the entire service area.
- 3.6. All field work shall be done between the hours of 8:00 A.M. to 5:00 P.M., Monday through Friday. No work shall occur on holidays.
- 3.7. Installer will be responsible for capturing field data in a format that will allow automated upload of required data into the District's billing software.
- 3.8. Contractor's license and registration with the California Department of Industrial Relations (DIR) are required to perform the installation portion of this proposal (this section). The District shall verify the current validity of the license with the California Contractors State License Board and the DIR registration as part of the award of contract process. This project is classified as a public works project and requires the payment of prevailing wages. Certified payroll submittals will be required.

General Specifications

1. Training / Customer Support / Documentation

- 1.1. The Vendor shall be responsible for supplying the AMI System components completely, including training and ensuring the proposed AMI System is operational prior to deployment. This includes support for the development of an interface to the utility billing system and functional testing of the system. The Vendor shall provide comprehensive training to the District's IT, Meter Department, and Utility Billing Specialist,

specifically addressing the procedures for connecting and uploading meter readings within the new AMI System to ensure its proper operation and integration with the utility billing system. Coordination with Tyler 10 Incode support will also be required.

- 1.2. The Vendor shall have a proven program of professional project management to ensure successful system installation. Provide resumes for key managers involved.
- 1.3. If additional project management and installation personnel or planning will be required as a result of the project timeline to be completed by February 2026, these plans shall be included in the proposal. The February 2026 completion date does not apply to training and customer support, which can occur after that date.
- 1.4. Project managers shall be experienced in managing the design, installation and optimization of systems. Project management experience shall include system integration and training support.
- 1.5. Include a material procurement timeline in the proposed schedule and discuss anticipated ground-breaking date.
- 1.6. List turnaround time for customer service regarding:
 - 1.6.1. Phone Inquiry
 - 1.6.2. Field fix for End Point Transmission Device, Cellular Network, Data Collector or Server
- 1.7. Prepare and provide a hard copy and an electronic copy of an Operation and Maintenance Manual for the completed installation. Hard copy is to be provided in a three-ring binder. The electronic copy is to be submitted via a PDF file on a media to be determined by the District. The Operation and Maintenance Manual will include cut sheets and other equipment documentation.

2. Warranty

- 2.1. Provide the warranties and any services, including additional costs, your firm will offer to ensure system functionality and availability of system components for 15 years.
- 2.2. At a minimum, a 100% warranty on all equipment, software and labor on the AMI System will be in effect during the first 24 months following commissioning and acceptance.
- 2.3. The End Point Transmission Devices and Data Collectors shall have a 100% product warranty of at least 15 years from date of installation

against any defects in materials and workmanship. The End Point Transmission Device and Data Collector Battery shall have 100% warranty for 15 years from date of delivery. Additionally, the End Point Transmission Device and Data Collector Battery and electronics shall be warranted for an additional 5 years at a prorated replacement cost. The total warranted life of the End Point Transmission Device shall be 20 years.

- 2.4. Provide a price for software support and upgrades following the initial warranty period.

EXHIBIT B

NCCWD EXAMPLE CONTRACT

CONTRACT FOR MINOR PUBLIC WORKS PROJECTS

THIS CONTRACT is made as of this _____ day of _____ 2025, by and between North Coast County Water District (“DISTRICT”) and, _____ (“CONTRACTOR”).

THE PARTIES AGREE AS FOLLOWS:

1. SCOPE OF WORK

In consideration of the DISTRICT’s obligations set forth herein, the CONTRACTOR shall furnish the tools, equipment, labor and material necessary to perform as set forth in Exhibit A and complete in a good and workman- like manner, retrofit and replacement of DISTRICT’s existing water meters and implementation of a fully functional Advanced Metering Infrastructure (AMI) system. The CONTRACTOR shall perform the Work in accordance with the terms of this Agreement (including Exhibit “A,” attached hereto and incorporated herein by reference), and at the compensation rates and charges set forth on Exhibit “A,” attached hereto and incorporated herein by reference. Exhibit “A” consists of the CONTRACTOR’s original proposal and scope of work details, which are made a part of and together herewith constitute the contract.

By execution of this Contract, CONTRACTOR warrants that it has carefully examined the site of the Work contemplated and any plans and specifications and contract documents pertaining to the Work and has satisfied itself of all local conditions affecting the Work and delivery of materials; DISTRICT specifically disclaims any warranties for information provided to CONTRACTOR. It is the obligation of CONTRACTOR to notify DISTRICT of any and all ambiguities, conflicts, etc., in and among such plans, specifications and/or documents.

All of the work performed pursuant to this Agreement shall be under the supervision of, and performed to the satisfaction of, the assigned representative(s) of the DISTRICT.

2. SCHEDULE and TERM

CONTRACTOR shall begin work upon completion of fully executed Agreement. shall expire on February 28, 2026 (the “Termination Date”) unless extended by written agreement of the parties or terminated earlier. CONTRACTOR may request extensions of time to perform the services required hereunder. Such extensions shall be effective if authorized in advance by DISTRICT in writing and incorporated in written amendments to this agreement.

3. COMPENSATION

CONTRACTOR shall perform all work set forth in Exhibit A for a sum not to exceed _____ (\$ _____) Dollars. The total Contract Amount shall include all labor, materials, taxes, insurance, subcontractor costs, overhead and profit, and all other costs and expenses incurred by CONTRACTOR.

4. MANNER OF PAYMENT

Once each month, at a time, place and location mutually agreeable, the CONTRACTOR and DISTRICT or the DISTRICT’s representative shall meet to discuss the amount of work completed satisfactorily during the work period since the last invoice for partial payment was prepared. The first such estimate will be of the value of the work done after the

CONTRACT FOR MINOR PUBLIC WORKS PROJECTS

CONTRACTOR commenced the performance of the contract, and every subsequent estimate, except the final estimate, will be of the value of the work done after that included in the last preceding estimate. Such estimates need not be based on strict measurements, but may be approximate only, and will be in due proportion to the whole amount of money, including payments previously made, that will have become due according to the contract when all work required under the contract shall have been completed. A draft invoice for work completed shall be prepared. In accordance with Public Contract Code §20104.50, DISTRICT shall promptly review payment requests and if not suitable for payment, DISTRICT shall no later than seven (7) days after receipt return the same with an explanation as to why the payment request is not possible. DISTRICT shall make progress payments within thirty (30) days after receipt of an undisputed and properly executed request.

5. ASSIGNMENT

CONTRACTOR shall not assign any of the rights nor transfer any of its obligations under the Agreement without the prior written consent of the DISTRICT.

6. USE OF SUBCONTRACTORS

CONTRACTOR shall not subcontract any services to be performed by it under this Agreement without the prior written approval of the DISTRICT. All subcontractors must be registered with the Department of Industrial Relations (DIR) and upload all appropriate Prevailing Wages data to the DIR database.

7. CHANGES

Should the DISTRICT at any time during the progress of the Work request any alterations, deviations, additions or omissions from said Contract, specifications or plans, it shall be at liberty to do so, and the same shall in no way affect or make void the Contract, but will be added to or deducted from the amount of said contract price, as the case may be, by fair and reasonable valuation. The value of any such extra work or change shall be determined in one or more of the following ways:

- A. By estimate and acceptance of a lump sum.
- B. By unit price named in the contract or subsequently agreed upon.
- C. By cost and percentage or by cost and a fixed fee.

8. PREVAILING WAGES AND COMPLIANCE WITH CALIFORNIA LABOR CODE

The CONTRACTOR shall comply with California Labor Code Sections 1770 to 1780, inclusive. In accordance with said Section 1775, the CONTRACTOR shall forfeit as a penalty to the DISTRICT \$50 for each calendar day or portion thereof for each workman paid less than stipulated prevailing wage rates for such work or craft in which such worker is employed for any work done under the Contract by him or by any subcontractor under him in violation of the provisions of the Labor Code and in particular, Labor Code Sections 1770 to 1780, inclusive. In addition to said penalty and pursuant to said Section 1775, the difference between such stipulated prevailing wage rates and the amount paid to each worker for each calendar day or

North Coast County Water District
Advanced Metering Infrastructure Project

CONTRACT FOR MINOR PUBLIC WORKS PROJECTS

portion thereof for which each worker was paid less than the stipulated prevailing wage rate shall be paid to each worker by the CONTRACTOR. Pursuant to the provisions of Section 1773 of the Labor Code, the DISTRICT has obtained the general prevailing rate of per diem wages and the general prevailing rate for holiday and overtime work applicable to the work to be done from the Director of the Department of Industrial Relations. Such wage rates must be prominently posted at the construction site. The DISTRICT will not recognize any claim for additional compensation because of the payment by the CONTRACTOR of any wage rate in excess of the prevailing wage rate set forth in the Contract. The possibility of wage increases is one of the elements to be considered by the CONTRACTOR in determining their bid and will not under any circumstances be considered as the basis of a claim against the DISTRICT on the Contract.

A. CONTRACTOR shall comply with Section 1776 relating to certified copies of payroll records including the maintenance of these records and their certification and availability for inspection.

B. CONTRACTOR agrees to comply with Sections 1777.5, 1777.6 and 1777.7 regarding employment of apprentices. The responsibility for compliance with these provisions is fixed with the prime contractor for all occupations.

C. In the event the Work involves the excavation of any trench(es) five (5) feet or more in depth, CONTRACTOR shall submit a detailed plan showing the design of shoring, bracing, sloping or other provisions to be made for worker protection from the hazard of caving ground during the excavation of such trench(es) in accordance with Section 6705.

D. Pursuant to requirements under the California Labor Code, CONTRACTOR hereby acknowledges its affirmative obligations related to the Department of Industrial Relations (DIR) compliance and enforcement efforts with respect to prevailing wage requirements on public works projects. No CONTRACTOR or subcontractor may be listed on a bid proposal for a public works project unless registered with the DIR pursuant to Labor Code section 1725.5 [with limited exceptions from this requirement for bid purposes only under Labor Code section 1771.1 (a)]. CONTRACTOR and Subcontractors may register with the DIR at <https://efiling.dir.ca.gov/PWCR/ActionServlet?action=displayPWCRRegistrationForm>. No CONTRACTOR or subcontractor may be awarded a contract for public work on a public works project unless registered with DIR pursuant to Labor Code section 1725.5.

This construction of the improvements under this Agreement is subject to compliance monitoring and enforcement by the DIR.

E. The CONTRACTOR assures payment of a minimum wage rate to employees as defined by the California Labor Code.

F. The CONTRACTOR, whether an employer, as defined in the Labor Code, or any other person employing individuals, shall not discharge, reduce in compensation, or otherwise discriminate against any employee for complaining to the DISTRICT with regard

North Coast County Water District
Advanced Metering Infrastructure Project

CONTRACT FOR MINOR PUBLIC WORKS PROJECTS

to the employer's compliance or anticipated compliance with the Labor Code.

G. Any Subcontract entered into by the CONTRACTOR relating to this Agreement shall be subject to the provisions of the Labor Code.

H. The CONTRACTOR shall, immediately upon execution of Contract, provide notification to all affected employees of the wage required to be paid pursuant to the Labor Code.

I. The CONTRACTOR shall provide, upon demand by DISTRICT, documents and information verifying compliance with the requirements of the Labor Code.

J. The DISTRICT shall have the authority, under appropriate circumstances, to terminate this contract and otherwise pursue legal remedies that may be available if the DISTRICT determines that the subject CONTRACTOR has violated provisions of the Labor Code.

K. Attention is directed to Section 1735 of the Labor Code which provides the CONTRACTOR shall not discriminate against any employee who is employed on the work because of race, religious creed, color, national origin, ancestry, physical handicap, mental disability, medical condition, genetic information, marital status, sex gender, gender identity, gender expressing age or sexual orientation of such persons, except as provided in Section 12940 of the Government Code.

9. **EIGHT HOUR DAY LIMITATION**

CONTRACTOR agrees that eight (8) hours labor shall constitute a day's work, and no worker, in the employ of the CONTRACTOR, or any subcontractor, doing or contracting to do any part of the work under this Agreement, shall be required or permitted to work more than eight (8) hours in any one calendar day and forty (40) hours in any one calendar week; provided that subject to California Labor Code Section 1815, a worker may perform work in excess of eight (8) hours per day or forty (40) hours per week at not less than one and one-half times the basic rate of pay.

Except as provided above for overtime, CONTRACTOR shall forfeit as a penalty to DISTRICT the sum of Twenty-Five Dollars (\$25.00) for each worker employed in the execution of this Agreement by CONTRACTOR or by any subcontractor under it for each calendar day during which such worker is required or permitted to work more than eight (8) hours in any one day and forty (40) hours in any one calendar week in violation of California Labor Code Sections 1810 through 1815.

10. **RESPONSIBILITY: INDEMNIFICATION**

The following shall govern the responsibilities and indemnification by CONTRACTOR:

A. The CONTRACTOR shall at all times observe, and shall cause all their

North Coast County Water District
Advanced Metering Infrastructure Project

CONTRACT FOR MINOR PUBLIC WORKS PROJECTS

agents and employees to observe, all such requirements of laws and shall protect, indemnify and hold harmless the DISTRICT and its directors, officers, agents, engineer, and employees against all claims and liabilities arising from or based on the violation of any such requirement of law whether by the CONTRACTOR or their employees. If any discrepancy or inconsistency is discovered in the Agreement for the Work in relation to any such requirements of laws, the CONTRACTOR shall immediately report the same to the DISTRICT in writing. The Agreement shall be governed by the laws of the State of California.

B. The CONTRACTOR shall assume all costs arising from the use of patented materials, equipment, devices or processes, used on or incorporated in the Work and shall indemnify and save harmless the DISTRICT and its directors, officers, agents, engineer, and employees against all suits at law, or actions of every nature for, or on account of, the use of patented materials, equipment, devices or processes. In case such materials, equipment, devices or processes are held to constitute an infringement and their use enjoined, the CONTRACTOR, at their expense, shall: (a) secure for the DISTRICT the right to continue using said materials, equipment, devices or processes by suspension of the injunction or by procuring a license or licenses, or (b) replace such materials, equipment, devices or processes, or (c) modify them so that they become non-infringing or remove the enjoined materials, equipment, devices or processes and refund the sums paid therefore without prejudice to any other rights of the DISTRICT.

C. The DISTRICT and all Directors, officers, employees and authorized agents thereof, and the Engineer, connected with the work shall not be answerable or accountable in any manner: for any loss or damage that may happen to the work or any part thereof; for any loss or damage to any of the materials or other things used or employed in performing the work; for injury to or death of any person (including but not limited to workers or the public) from any cause whatsoever; or damage to property from any cause whatsoever.

The CONTRACTOR shall be responsible for any liability imposed by law and injuries to or death of any person (including but not limited to workers and the public) or damage to property resulting from defects or obstructions or from any cause whatsoever during the progress of the work or at any time before its completion and final acceptance.

To the maximum extent permitted by law, the CONTRACTOR shall indemnify and save harmless the DISTRICT and all Directors, officers, employees and authorized agents thereof, and the Engineer, from all claims, suits or actions of every name, kind and description, brought for, or on account of, injuries to or death of any person (including but not limited to employees of CONTRACTOR, of subcontractors, or of any other person, firm or entity and the public) or damage to property arising from any cause whatsoever during the progress of the work or at any time before its final completion and acceptance. The duty of the CONTRACTOR to indemnify and save harmless includes the duties to defend (by legal counsel satisfactory to the indemnitees) as set forth in Section 2778 of the Civil Code and to pay attorney's fees and litigation costs required by such defense.

CONTRACT FOR MINOR PUBLIC WORKS PROJECTS

With respect to third party claims against CONTRACTOR, the CONTRACTOR waives any and all rights to any type of express or implied indemnity against the DISTRICT, its Directors, officers, employees or authorized agents, or the Engineer. It is the intent of the parties that the CONTRACTOR shall indemnify and hold harmless the DISTRICT, its Directors, officers, employees and authorized agents, and the Engineer, from any and all claims, suits, or actions arising from any cause whatsoever as set forth above regardless of the existence or degree of fault or negligence on the part of the DISTRICT, the Engineer, the CONTRACTOR, a subcontractor or employee of any of these, other than the active negligence of the DISTRICT or its Directors, officers, employees or authorized agents, or the Engineer.

11. INSURANCE

A. Workers' Compensation: CONTRACTOR shall procure and maintain at all times during the performance of such work Workers' Compensation Insurance in conformance with the laws of the State of California and Federal laws where applicable and Employers' Liability Insurance, which shall not be less than One Million Dollars (\$1,000,000) per accident or disease.

B. Contractor's Liability Insurance: CONTRACTOR also shall procure and maintain at all times during the performance of this Contract Liability Insurance with a limit for each occurrence of Five Million Dollars (\$5,000,000) or the full per occurrence limits of the policies available, whichever is greater for, naming as additional insureds, in connection with CONTRACTOR's activities, the DISTRICT and its directors, officers, employees, and engineer and agents.

C. Automobile Liability Insurance: CONTRACTOR also shall procure and maintain at all times during the performance of this Contract Automobile Liability Insurance covering all automobiles owned, hired, or leased by CONTRACTOR with a limit of One Million Dollars (\$1,000,000) for each accident naming the DISTRICT, and its directors, officers, employees and agents as additional insureds.

The CONTRACTOR's Liability and Automobile Liability Insurance policies will be primary insurance and the insurance companies providing such policies will be liable for the full amount of any loss or claim which CONTRACTOR is liable up to and including the total limit of liability, without right of contribution from any other insurance effected or which may be effected by the DISTRICT.

Inclusion of the DISTRICT as an additional insured shall not in any way affect its rights as respects to any claim, demand, suit or judgment made, brought or recovered against CONTRACTOR. The policy shall protect CONTRACTOR and the DISTRICT in the same manner as though a separate policy had been issued to each, but nothing in said policy shall operate to increase the Insurer's liability as set forth in the policy beyond the amount or amounts shown or to which the Insurer would have been liable if only one interest had been named as an insured. Such insurance shall also contain a waiver of subrogation in favor of the DISTRICT and its directors, officers, and employees while acting in such capacity, and their successors and assignees, as they now, or as they may hereafter be constituted, singly, jointly or severally

Prior to commencement of work under this Agreement by any such employee, CONTRACTOR shall deliver to the DISTRICT a Certificate of Insurance which shall stipulate that thirty (30) days

North Coast County Water District
Advanced Metering Infrastructure Project

CONTRACT FOR MINOR PUBLIC WORKS PROJECTS

advance written notice of cancellation, non-renewal or reduction in limits shall be given to the DISTRICT. Such insurance shall also contain a waiver of subrogation in favor of the DISTRICT and its directors, officers, and employees while acting in such capacity, and their successors and assignees, as they now, or as they may hereafter be constituted, singly, jointly or severally.

D. Deductibles and Retentions. CONTRACTOR shall be responsible for payment of any deductible or retention on CONTRACTOR's policies without right of contribution from the DISTRICT. Deductible and retention provisions shall not contain any restrictions as to how or by whom the deductible or retention is paid. Any deductible or retention provision limiting payment to the Named Insured is unacceptable.

In the event that the policy of the CONTRACTOR or any subcontractor contains a deductible or self-insured retention, and in the event that the DISTRICT seeks coverage under such policy as an additional insured, CONTRACTOR shall satisfy such deductible or self-insured retention to the extent of loss covered by such policy for a lawsuit arising from or connected with any alleged act or omission of CONTRACTOR, subcontractor, or any of their officers, directors, employees, agents, or suppliers, even if CONTRACTOR or subcontractor is not a named defendant in the lawsuit.

E. General Insurance Conditions. All policies will be issued by insurers acceptable to the DISTRICT. The insurance will be issued by an insurance company authorized to do business in the State of California with a minimum "Best's" rating of no less than A:VII, or equivalent, or as otherwise approved by the DISTRICT. Worker's Compensation coverage requirements may be met with the California State Compensation Fund.

F. Subcontractors. Consultant shall require and verify that all subcontractors maintain insurance meeting all the requirements stated herein, and Consultant shall ensure that the DISTRICT is an additional insured on insurance required from subcontractors.

12. BONDS

Concurrently with the execution of this Agreement, Applicant shall furnish to DISTRICT the following bonds:

A. Payment Bond: in the sum of _____ Dollars (\$_____), which shall be 100% of the cost of equipment and installation of the fully functioning AMI System to guarantee payment of the obligations referred to in Section 3248 of the Civil Code.

B. Performance Bond: in the same sum as the payment bond to guarantee the faithful performance of the terms of this Agreement; and

The bonds shall be in a form satisfactory to DISTRICT. The surety or sureties must be qualified to do business in California. If any of the sureties, in the sole opinion of DISTRICT, is or becomes irresponsible, DISTRICT may require other or additional sureties which CONTRACTOR shall furnish to the satisfaction of DISTRICT within ten (10) days after notice from DISTRICT. In default thereof, DISTRICT shall be released from all obligations under this Agreement. No prepayment or delay in payment and no change, extension, addition,

CONTRACT FOR MINOR PUBLIC WORKS PROJECTS

or alteration or any provision of this Agreement and no forbearance or acceptance by or on the part of DISTRICT shall operate to release any surety from liability on a bond.

13. TERMINATION

A. Whenever, in the opinion of the DISTRICT, the CONTRACTOR is neglecting the Work or is not prosecuting the same with diligence or is not fulfilling the provisions of the Contract and specifications, the Work, wholly or in part, may be suspended by written order of the DISTRICT. If the CONTRACTOR, within ten (10) days after the date of receipt of such a written order, does not agree to provide the required remedies for such deficiencies, the DISTRICT may declare this Contract terminated and itself proceed to complete the Work herein specified or engage others to do the same. The cost of such Work and necessary materials shall be charged against the CONTRACTOR and be deducted from next or subsequent estimate payment for same. If payments to CONTRACTOR are not sufficient to cover the charges, the balance may be recovered from the CONTRACTOR or its Sureties. If DISTRICT declares the Contract terminated pursuant to this paragraph and the amount of any such charges is less than the amount which would have been due to CONTRACTOR upon completion of the Work by it, the difference shall be paid it by DISTRICT; should the amount of said charges exceed the latter, the difference shall be paid by CONTRACTOR to DISTRICT.

B. In the event DISTRICT declares this Contract terminated pursuant to the previous paragraph, CONTRACTOR shall discontinue Work, and DISTRICT reserves the further right to take possession of and use any materials or equipment of any nature whatsoever belonging to or used by the CONTRACTOR on the Work. All expenses charged under this paragraph shall be deducted and paid by DISTRICT out of any monies due CONTRACTOR under the Contract, and in such accounting DISTRICT shall not be held to obtain the lowest figure for completing the Contract, but all sums actually paid therefore shall be charged to the CONTRACTOR.

14. CONTRACTOR'S STATUS

Neither the CONTRACTOR nor any party contracting with the CONTRACTOR shall be deemed to be an agent or employee of the DISTRICT. The CONTRACTOR is and shall be an independent CONTRACTOR, and the legal relationship of any person performing services for the CONTRACTOR shall be one solely between said parties.

15. FAILURE TO COMPLETE CONTRACT – EFFECT

Should the CONTRACTOR fail to complete this Contract with the time fixed for completion, due allowance being made for unavoidable delays, it shall become liable to DISTRICT in the amount of \$100 in Liquidated Damages per calendar day for each day said Work remains incomplete beyond the time for completion. If it appears to the CONTRACTOR that it will not complete the Work in the time agreed, it shall make written application to DISTRICT at least ten (10) calendar days prior to expiration of the time for completion, stating the reasons why and the amount of extension it believes should be granted. The DISTRICT may then, with discretion, grant, or deny such extension. Any money due or to become due to CONTRACTOR may be retained to cover the liquidated damages, and should such money not be sufficient to cover such damages, the DISTRICT shall have the right to recover the balance

CONTRACT FOR MINOR PUBLIC WORKS PROJECTS

from CONTRACTOR or its Sureties.

16. DISTRICT REPRESENTATIVE

Except when approval of other action is required to be given or taken by the Board of Directors of the DISTRICT, the General Manager of the DISTRICT, or such person or persons as he shall designate in writing from time to time, shall represent and act for the DISTRICT.

17. EXECUTION OF WORK

A. The CONTRACTOR shall have full care, custody and control of the project to completion and shall maintain the same in a safe and tidy condition. The CONTRACTOR shall at all times maintain proper facilities and provide safe access for inspection by DISTRICT to all parts of the Work, and to the shops wherein the Work is in preparation. Where the specifications require Work to be specially tested or approved, it shall not be tested or covered up without timely notice to the DISTRICT, or its representative, of its readiness for inspection, and without the approval thereof or consent thereto by the latter. Should any Work be covered up without such notice, approval or consent, it must, if required by the DISTRICT, or its representative, be uncovered for examination at the CONTRACTOR's expense.

B. The CONTRACTOR shall assume sole and complete responsibility for job site conditions for the duration of the project including, but not limited to, the safety and health conditions on the Work site. This requirement shall apply continuously and shall not be limited to normal working hours. CONTRACTOR shall comply with all applicable provisions of law including the standards, rules, regulations and orders established by the California Division of Industrial Safety. CONTRACTOR shall furnish and use safety devices and safeguards and shall adopt and use practices, means, methods, operations, and processes which are reasonably adequate to render the Work site safe and healthful. CONTRACTOR shall take all steps necessary to ensure that any hazardous condition is corrected promptly either by the CONTRACTOR or by assigning such responsibility to the appropriate subcontractor and ensuring that the corrections are completed. The DISTRICT, engineer, construction manager and the officers, agents or employees, shall not have control over or charge of or responsibility for construction or safety means, methods, techniques, procedures, as these are solely the responsibility of CONTRACTOR.

C. CONTRACTOR warrants to DISTRICT that all materials and equipment furnished under this CONTRACT will be new unless otherwise specified and that all Work will be of good quality free from faults and defects and in conformance with the contract documents. Neither final payment nor use or occupancy of the Work performed by the CONTRACTOR shall constitute an acceptance of Work not done in accordance with the Contract or relieve CONTRACT of liability in respect to any express warranties or responsibilities for faulty workmanship. CONTRACTOR shall remedy any defects in the Work

CONTRACT FOR MINOR PUBLIC WORKS PROJECTS

and pay for any damage resulting from faulty workmanship which shall appear within the period of two (2) years from the date of final payment by the DISTRICT for the Work. DISTRICT will give notice of observed defects with reasonable promptness. All materials are covered by the manufacturer's warranty only. With respect to the materials furnished hereunder, CONTRACTOR hereby disclaims all expressed or implied warranties, whether implied by operation of law or otherwise, including, without limitation, all implied warranties of merchantability and fitness or fitness for a particular purpose.

D. CONTRACTOR shall give its personal attention to the fulfillment of the Contract and shall keep the Work under its control at all times. No subcontractor will be recognized as such, and all persons engaged in the Work will be considered as employees of CONTRACTOR, and it will be held responsible for the Work which shall be subject to the provisions of the Contract and specifications, if any.

18. COMPLIANCE WITH LAWS AND REGULATIONS

A. During the progress of the work, CONTRACTOR shall fully adhere to all applicable State and Federal laws and county, municipal or DISTRICT ordinances and regulations which in any manner affect those engaged or employed in the Work, or the materials and equipment used in work, or which in any way affect the conduct of the work. CONTRACTOR, and any subcontractors performing any work under this Agreement, shall, at its sole cost and expense, hold such licenses, permits, qualifications, insurance, and approvals of whatsoever nature which are legally required for as may be required by the State of California for the performance of the work specified in this Agreement.

B. Construction working hours shall not extend beyond 7:00am to 6:00pm, Monday through Friday, without specific written permission from the DISTRICT AND City of Pacifica.

C. Workers' Compensation. CONTRACTOR certifies that it is aware of the provisions of the California Labor Code which require every employee to be insured against liability for workers' compensation or to undertake self-insurance in accordance with the provisions of that Code, and CONTRACTOR certifies that it will comply with such provisions before commencing performance of this Agreement and at all times in the performance of the Agreement.

D. Injury and Illness Prevention Program. CONTRACTOR certifies that it is aware of and has complied with the provisions of California Labor Code Section 6401.7, which requires every employer to adopt a written injury and illness prevention program.

E. Business Licenses. Except as otherwise allowed by DISTRICT in its sole discretion, bidders and their proposed subcontractors shall hold such licenses as may be required by the laws of the State of California for the performance of the work specified in the Contract Documents., prior to DISTRICT's issuance of an authorization to proceed with the Services. Such license(s) shall be kept valid throughout the term of this Agreement. DISTRICT may withhold compensation from CONTRACTOR until such time as CONTRACTOR complies with this section.

CONTRACT FOR MINOR PUBLIC WORKS PROJECTS

F. DISTRICT Not Responsible. The DISTRICT is not responsible or liable for CONTRACTOR's failure to comply with any and all of said requirements.

G. Completion of the Work shall be in conformance with applicable provisions of the DISTRICT Standard Plans and Specifications and City of Pacifica Standards.

19. SUBSURFACE EXCATIONS, NOTIFICATION

A. Attention is directed to Government Code Section 4216.2 which provides, in part:

"(a) Except in an emergency, every person planning to conduct any excavation shall contact the appropriate regional notification center at least two working days but not more than 14 calendar days, prior to commencing that excavation, if the excavation will be conducted in an area which is known, or reasonably should be known, to contain subsurface installations other than the underground facilities owned or operated by the excavator and, if practical, the excavator shall delineate with white paint or other suitable markings the area to be excavated.

(b) The regional notification center shall provide an inquiry identification number to the person who contacts the center and shall notify any member, if known, who has a subsurface installation in the area of the proposed excavation."

The CONTRACTOR shall contact the regional notification center, "Underground Service Alert," and schedule the work to allow ample time for the center to notify its members and, if necessary, for any member to field locate and mark its facilities.

B. The following provisions, drawn from Section 7104 of the Public Contracts Code, shall apply to any work which involves digging trenches or other excavations which extend deeper than four (4) feet below the surface:

(a) the CONTRACTOR shall promptly, and before the following conditions are disturbed, notify the DISTRICT, in writing, of any:

(1) Material that the CONTRACTOR believes may be material that is hazardous waste, as defined in Section 25117 of the Health and Safety Code, that is required to be removed to a Class I, Class II, or Class III disposal site in accordance with provisions of existing law.

(2) Subsurface or latent physical conditions at the site differing from those indicated.

(3) Unknown physical conditions at the site of any unusual nature, different materially from those ordinarily encountered and generally recognized as inherent in work of the character provided for in the contract.

(b) The DISTRICT shall promptly investigate the conditions, and if it finds that the conditions do materially so differ, or do involve hazardous waste, and cause a decrease or

CONTRACT FOR MINOR PUBLIC WORKS PROJECTS

increase in the CONTRACTOR's cost of, or the time required for, performance of any part of the work shall issue a change order under the procedures described in the contract.

(c) In the event that a dispute arises between the DISTRICT and the CONTRACTOR as to whether the conditions materially differ, or involve hazardous waste, or cause a decrease or increase in the CONTRACTOR's cost of, or time required for, performance of any part of the work, the CONTRACTOR shall not be excused from any scheduled completion date provided for by the Contract, but shall proceed with all work to be performed under the Contract. The CONTRACTOR shall retain any and all rights provided either by contract or by law which pertain to the resolution of disputes and protests.

20. CLAIMS

A. CONTRACTOR shall not be entitled to the payment of any additional compensation for any act, or failure to act, by the DISTRICT, including failure or refusal to issue a change order, or for the happening of any event, thing, occurrence, or other cause, unless he/she shall have given the DISTRICT due written notice of potential claim. The written notice of potential claim shall set forth the reasons for which the CONTRACTOR believes additional compensation will or may be due, the nature of the costs involved, and insofar as possible, the amount of the potential claim. The said notice as above required must have been given to the DISTRICT prior to the time that the CONTRACTOR shall have performed the Work giving rise to the potential claim for additional compensation if based on an act, or failure to act, by the DISTRICT, or in all other cases within fifteen (15) days after the happening of the event, thing, occurrence, or other cause giving rise to the potential claim.

B. This contract is further subject to the provisions of Article 1.5 (commencing at Section 20104) of Division 2, Part 3 of the California Public Contract Code regarding the resolution of public works claims of less than \$375,000. Article 1.5 mandates certain procedures for the filing of claims and supporting documentation by the CONTRACTOR, for the response to such claims by the contracting public agency, for a mandatory meet and confer conference upon the request of the CONTRACTOR, for mandatory nonbinding mediation in the event litigation is commenced, and for mandatory judicial arbitration upon the failure to resolve the dispute through mediation. This contract hereby incorporates the provisions of Article 1.5 as though fully set forth herein.

21. NOTICES

All notices and communications deemed by either party to be necessary or desirable to be given to the other party may be given by personal delivery to the representative of the parties or by mailing the same postage prepaid, addressed as follows:

North Coast County Water District
Advanced Metering Infrastructure Project

CONTRACT FOR MINOR PUBLIC WORKS PROJECTS

If to the DISTRICT: North Coast County Water District
P.O. Box 1039
Pacifica, CA 94044-6039
Attn: General Manager

If to the CONTRACTOR: [CONTRACTOR ADDRESS]

The address to which mailings may be made may be changed from time to time by notice mailed as described above. Any notice given by mail shall be deemed given on the day after that on which it is deposited in the United States Mail as provided above.

22. ATTORNEY'S COSTS

If any legal proceeding should be instituted by either of the parties hereto to enforce the terms of this Agreement or to determine the rights of the parties thereunder, the prevailing party in said proceeding shall recover, in addition to all court costs, reasonable attorney's fees.

23. APPLICABLE LAW

This Agreement, its interpretation and all work performed thereunder, shall be governed by the laws of the State of California.

24. BINDING ON SUCCESSORS

All of the terms, provisions and conditions of this Agreement shall be binding upon and inure to the benefit of the parties hereto and their respective successors, assigns and legal representatives.

25. OWNERSHIP OF WORK

A. All reports, designs, drawings, plans, specifications, schedules, and other materials prepared by CONTRACTOR under this Agreement ("Work Product") shall be the property of DISTRICT.

B. CONTRACTOR assigns to DISTRICT all right, title, and interest in and to the Work Product, including ownership of the entire copyright in the Work Product and any causes of action existing or arising in connection with the copyright to said Work Product. DISTRICT shall be entitled to access to and copies of these materials as they are being developed. Any such materials in the hands of CONTRACTOR or in the hands of any Subcontractor upon completion or termination of services hereunder shall be immediately delivered to DISTRICT.

North Coast County Water District
Advanced Metering Infrastructure Project

CONTRACT FOR MINOR PUBLIC WORKS PROJECTS

26. RELEASE OF INFORMATION

CONTRACTOR shall not release any reports or other materials prepared in connection with this Agreement without approval of DISTRICT's General Manager.

27. SEVERABILITY

Should any provision herein be found or deemed to be invalid, this Agreement shall be construed as not containing such provision, and all other provisions which are otherwise lawful shall remain in full force and effect, and to this end the provisions of this Agreement are declared to be severable.

IN WITNESS WHEREOF, the parties hereto have executed this Agreement as of the day and year first above written.

NORTH COAST COUNTY WATER DISTRICT

CONTRACTOR

By: _____
District Manager

By: _____
President or CEO

Date: _____

Date: _____

North Coast County Water District
Advanced Metering Infrastructure Project

CONTRACT FOR MINOR PUBLIC WORKS PROJECTS

Exhibit A

ORIGINAL PROPOSAL AND SCOPE OF WORK DETAILS

EXHIBIT C

EXISTING DISTRICT SERVICE AREA MAP AND HYDRAULIC PROFILE

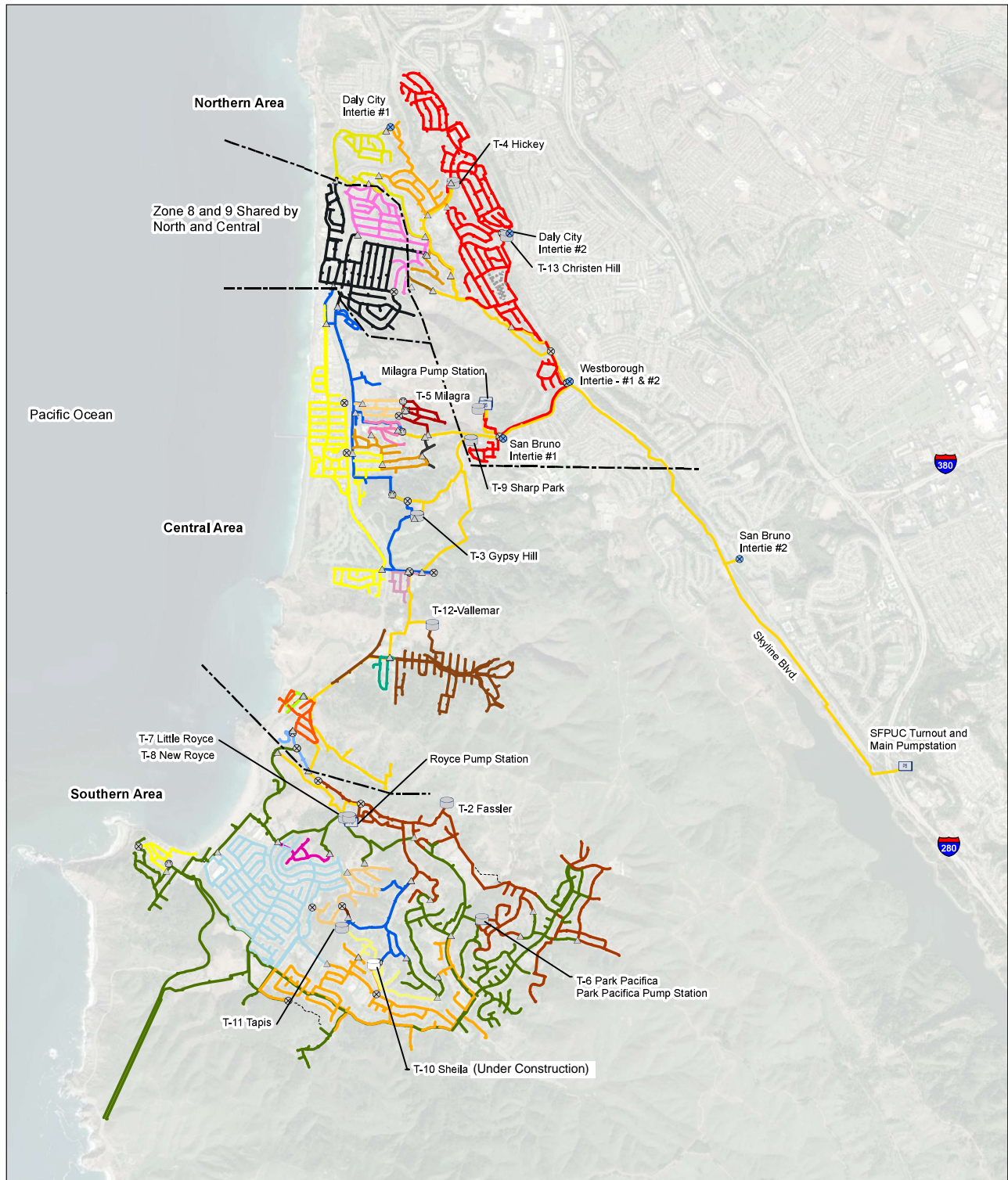

Path: C:\Users\spalmer\Desktop\CO0019\Map\Final\TM\Figure1_PipeZones.mxd

Legend

- Pressure Reducing Valve
- Tanks
- Pumps
- Closed Valves
- Intertie

Water System Distribution Piping Zones

	1		11		20		29
	2		12		21		30
	4		13		22		31
	5		14		23		32
	6		15		24		33
	7		16		25		
	8		17		26		
	9		18		27		
	10		19		28		

Abbreviations

"SFPUC" = San Francisco Public Utilities Commission

Notes

1. All locations are approximate.

Sources

1. Aerial base map provided by ArcGIS Online

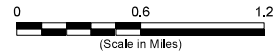

Water System Facilities Map

North Coast County Water District
 Pacifica, CA
 March 2021
 EK1 C00019.02



Figure 1

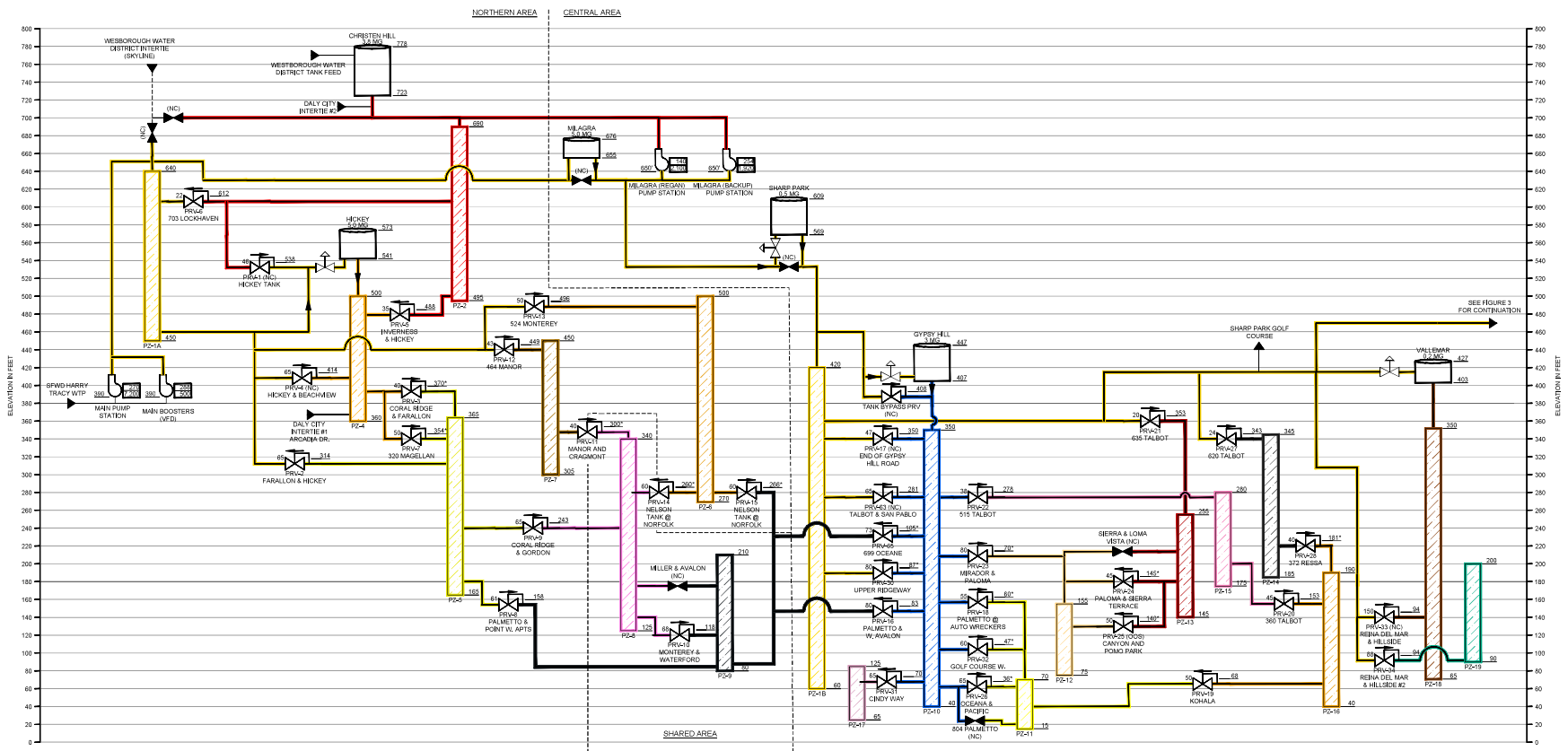

Legend:

- Tank with Volume (MG), Base and Top Elevation
- Pressure Reducing/Sustaining Valve with Elevation and Pressure Settings (psi)
- Closed Valve
- Check Valve
- Pump Station with Discharge Head (ft), Flow (gpm), and Base Elevation
- Pressure Zone with Highest and Lowest Elevation Served

Abbreviations:

- BPS = Booster Pump Station
- EL. = Elevation
- MG = Million Gallons
- NC = Normally Closed
- OOS = Out of Service
- PRV = Pressure Reducing Valve
- psi = Pounds Per Square Inch
- PZ = Pressure Zone
- UNK = Unknown
- V = Volume
- * = Approximate Elevation Shown

Notes:

1. All elevations are approximate.
2. Elevations are based on NAD88 vertical datum.
3. PRV settings have been updated based discussions with the District.

Sources:

1. 20-Year Long-Term Water Master Plan, Stetson Engineers Inc, February 2016.
2. District Water System Map.
3. Previous Hydraulic Profile - Kennedy/Jenks Consultants, Revised July 2000.

North Coast County Water District
Water System Schematic
Hydraulic Profile (North)



NCOWD
Pacifica, CA
March 2021
ENR 030019.02
Figure 2

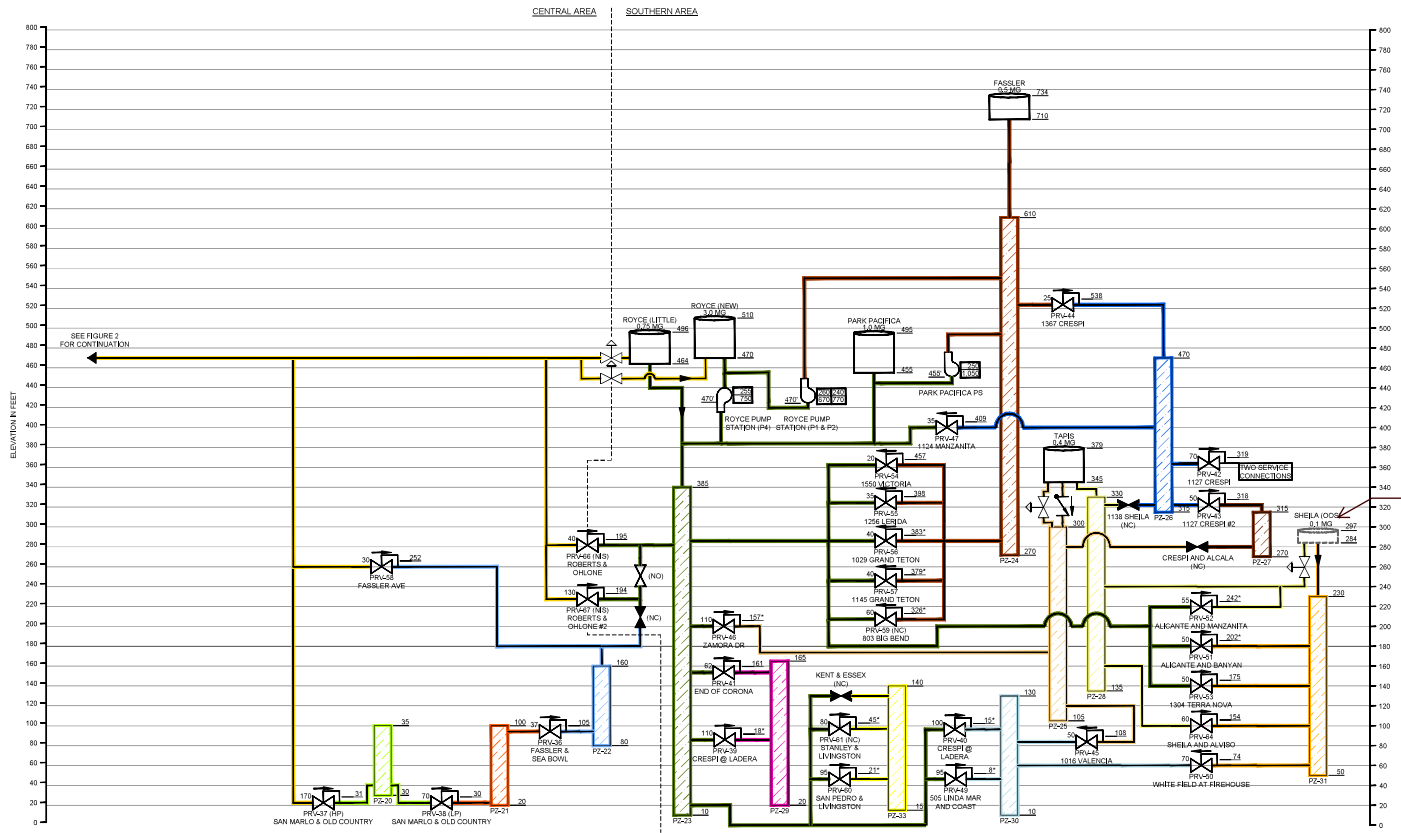

Replacement 0.6 MG Sheila Tank under construction and will have a max elevation of 324.5 ft. Project to be completed August 2025.

Legend:

- Tank with Volume (MG), Base and Top Elevation
- Pressure Reducing/Sustaining Valve with Elevation and Pressure Settings (psi)
- Closed Valve
- Check Valve
- Pump Station with Discharge Head (ft), Flow (gpm), and Base Elevation
- Pressure Zone with Highest and Lowest Elevation Served

Abbreviations:

- BPS = Booster Pump Station
- EL. = Elevation
- MG = Million Gallons
- NC = Normally Closed
- OOS = Out of Service
- PRV = Pressure Reducing Valve
- psi = Pounds Per Square Inch
- PZ = Pressure Zone
- UNK = Unknown
- V = Volume
- * = Approximate Elevation Shown

Notes:

1. All elevations are approximate.
2. Elevations are based on NAD88 vertical datum.
3. PRV settings have been updated based discussions with the District.

Sources:

1. 20-Year Long-Term Water Master Plan, Stetson Engineers Inc, February 2016.
2. District Water System Map.
3. Previous Hydraulic Profile - Kennedy/Jenks Consultants, Revised July 2000.

EXHIBIT D

STANDARD PRICING ESTIMATE FORM

Exhibit D: Standard Pricing Estimate Form

Item	Unit	Assumed Quantity	Unit Rate (\$)	Item Total (\$)
Base Scope: Retrofit all meters with an AMI-compatible endpoint or an AMI-compatible endpoint and a new register (including equipment and labor)	Meter	12,718		
AMI System Infrastructure: Provide and install system infrastructure including base stations, collectors and repeaters (including equipment and labor)	Lump Sum	1		
Software: Provide and install AMI system software and any other required software	Lump Sum	1		
Replacement of Meter Lids: If needed for AMI system functionality, replace selected existing meter lids with new meter lids (including equipment and labor – please fill in assumed quantity and provide unit rate even if assumed quantity is zero). New lids located in drive ways shall be traffic rated.	Lid			
Subscriptions: Include any subscription costs, including cellular subscriptions if applicable	Lump Sum	1		
Other: Include any other costs not listed above that are required for a fully-functioning AMI system	Lump Sum	1		
Subtotal				
Additive Alternate 1: Meter Replacement >15 Years: Replace meters older than 15 years or with unknown age (4,397 meters) with new AMI-compatible meters and endpoints (including equipment and labor – refer to Table 2 of the RFP for sizes of meters in this age range)	Lump Sum	1		
Additive Alternate 2: Meter Replacement 11-15 Years: Replace meters between 11 and 15 years (3,001 meters) with new AMI-compatible meters and endpoints (including equipment and labor – refer to Table 2 of the RFP for sizes of meters in this age range)	Lump Sum	1		
Additive Alternate 3: Meter Replacement 7-10 Years: Replace meters between 7 and 10 years (3,444 meters) with new AMI-compatible meters and endpoints (including equipment and labor – refer to Table 2 of the RFP for sizes of meters in this age range)	Lump Sum	1		
Additive Alternate 4: Meter Replacement 0-7 Years: Replace meters between 0 and 7 years (1,876 meters) with new AMI-compatible meters and endpoints (including equipment and labor – refer to Table 2 of the RFP for sizes of meters in this age range)	Lump Sum	1		